

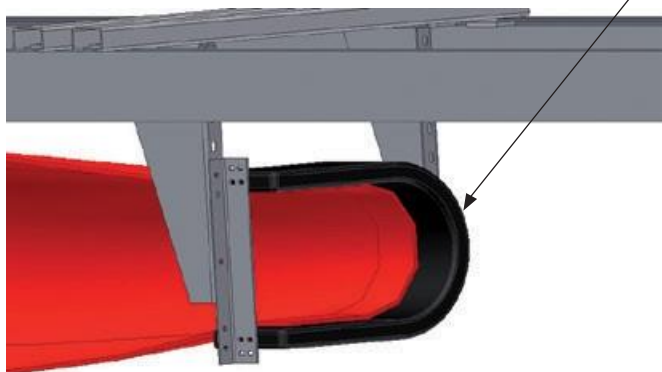

SPAR 3

Turnover U made from Polyspar



PRODUCT FEATURES

- Antifouling system eliminates the need for cleaning operations under the return idlers.
- Precision self-tracking mechanism prevents the belt from wandering, making belt alignment operations unnecessary.
- Available for belts measuring from 500 to 1200mm.

BELT TURNOVER SYSTEM

- The SPAR 3 is a highly effective belt turning system that prevents clogging on return idlers and accumulation of dirt underneath belt conveyors.
- It can be installed on almost any type of belt conveyor 40 meters or longer, with no need for special modifications.
- Belt twist process maintains the drive side of the belt clean and dry, improving the belt's grip on the driving pulley.

The SPAR 3 :

- limits the need for interventions by personnel near the conveyor, thus reducing the risk of accidents
- keeps the return idlers clean
- eliminates clogging and extends equipment life
- can be used with almost any type of belt conveyor and is approved by leading belt manufacturers

On stacking conveyors, the SPAR 3 prevents contamination of stockpiles under the conveyor.

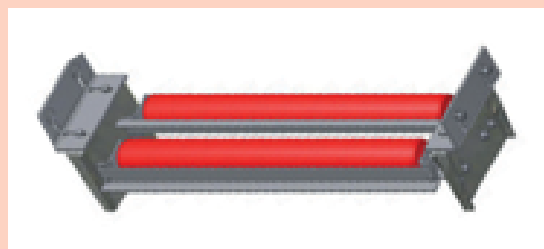

R. BRUNONE

CONTAINMENT • OPTIMISATION • SAFETY OF CONVEYORS

1, rue de la Cressonnière
27950 Saint-Marcel, France
Tél.: +33 (0)2 32 64 20 20
E-mail: commercial.brunone@brunone.fr