

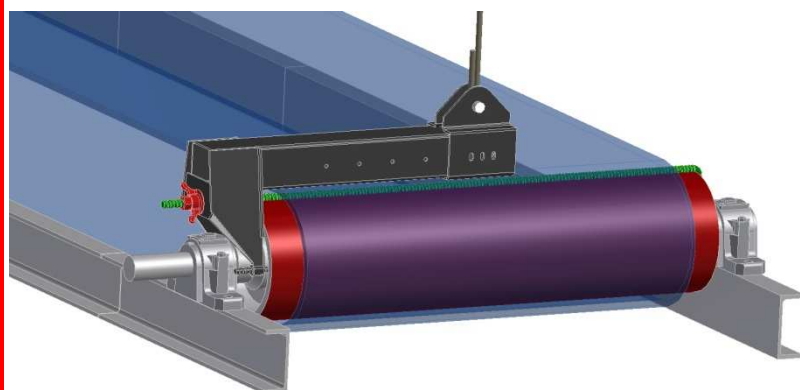

# DT SPAR

## Drum removal device



Patent N°1460905

### Fast and easy-to-use drum removal tool

The DT SPAR is a compact and innovative system, making faster and easier any drum removal operation on a belt conveyor.

The DT SPAR allows to remove the tail or head pulley without cutting the belt, in complete safety for the operators.

- ◆ The DT SPAR is designed for  $\varnothing 300$  to 800 mm drums and beyond on request.
- ◆ The design of the DT SPAR ensures a strong holding of the drum and allows to lift it in complete safety.

The DT SPAR provides an easy, quick and effective way to remove a drum from a belt conveyor.

The device has to be placed horizontally on the drum, then the holding rod has to be tightened on the drum.

Once the DT SPAR in place, the drum can be easily removed using a hoist or any other lifting system.

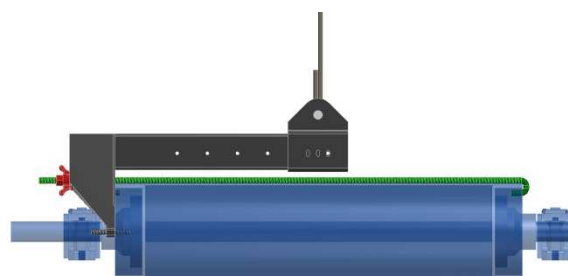

## R. BRUNONE

conveyor optimization and safety

1, rue de la Cressonnière  
BP 3353 – 27950 Saint-Marcel, France  
Ph.: +33 (0)2 32 64 20 20  
Fax: +33 (0)2 32 64 20 11  
E-mail: [brunone@brunone.fr](mailto:brunone@brunone.fr)  
Site : [www.brunone.fr](http://www.brunone.fr)